

1A Nickel-Metal Hydride Battery Charger IC CN3085

General Description:

CN3085 is a charger IC for single to three cell Nickel Metal Hydride (NiMH) batteries. The device contains an on-chip power MOSFET and eliminates the need for the external sense resistor and blocking diode. CN3085 requires few external components, and is suitable for portable applications. Thermal feedback regulates the charge current to limit the die temperature during high power operation or high ambient temperature. The CN3085 integrates a high precision reference voltage and amplifier, which can precisely regulate the charge voltage and charge current. The charge current can be set externally with a single resistor. When the input supply is removed, the CN3085 automatically enters a low power sleep mode, dropping the battery drain current to less than 3uA. Other features include undervoltage lockout, automatic recharge, the constant current charging, the maintenance charge mode(timer termination), charge/termination indicators and battery temperature monitoring.

The CN3085 is available in thermally-enhanced 8-pin SOP8 package. (SOP8/PP).

Applications:

- Digital Camera
- Electronic Dictionary
- Portable Devices
- Nickel Metal Hydride Battery Charger

Features:

- On-chip Power MOSFET
- Voltage accuracy: 1%
- Precharge Conditioning for reviving deeply discharged cells and minimizing heat dissipation during initial stage of charge
- Charge Current up to 1A
- Constant-Current/Constant-Temperature operation with thermal regulation to maximize charge rate without risk of overheating
- Automatic Low-Power Sleep Mode when input supply voltage is removed
- Indicators for Charge and termination status
- Maintenance Charge Mode(Timer Termination)
- Automatic Recharge
- Battery Temperature Monitoring
- Available in SOP8/PP Package
- Pb-free, rohs compliant and Halogen free

Pin Assignment

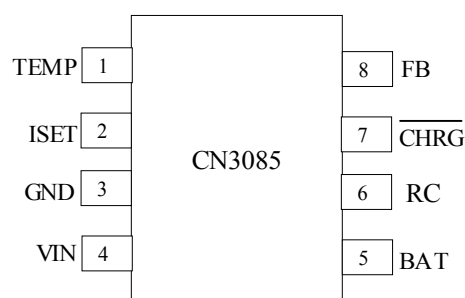

CONSONANCE

Typical Application Circuit

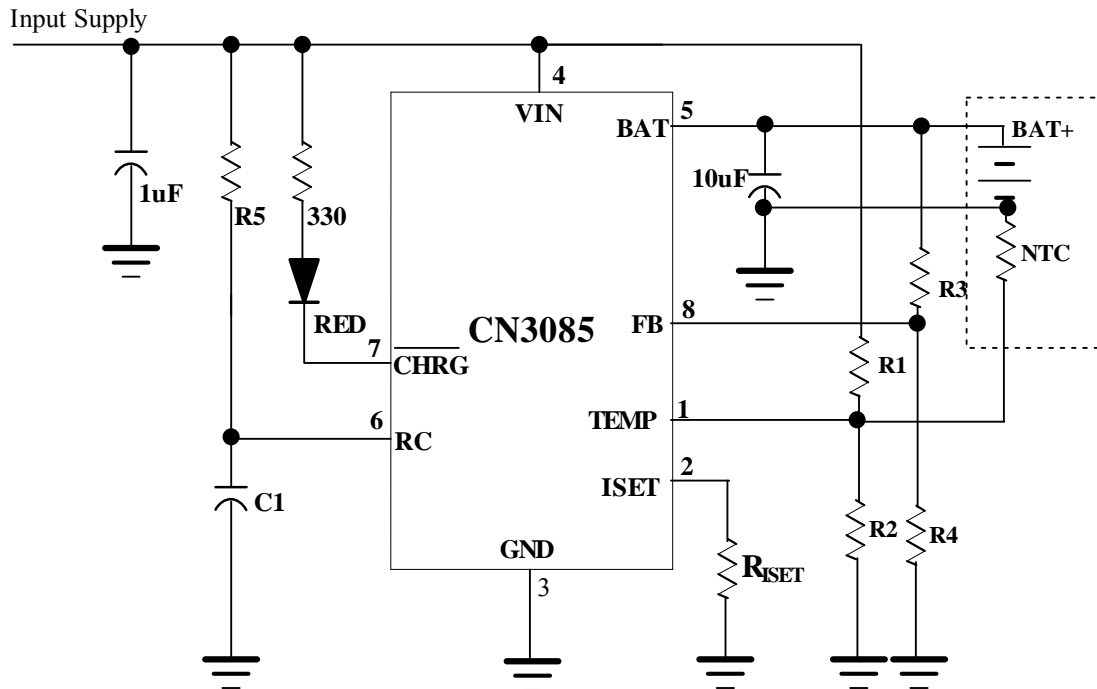

Figure 1 Typical Application Circuit

Ordering Information

Part Number	Package	Operating Ambient Temperature	Tape and Reel
CN3085	SOP8/PP	-40°C to 85°C	2500pcs / Reel

CONSONANCE

Block Diagram

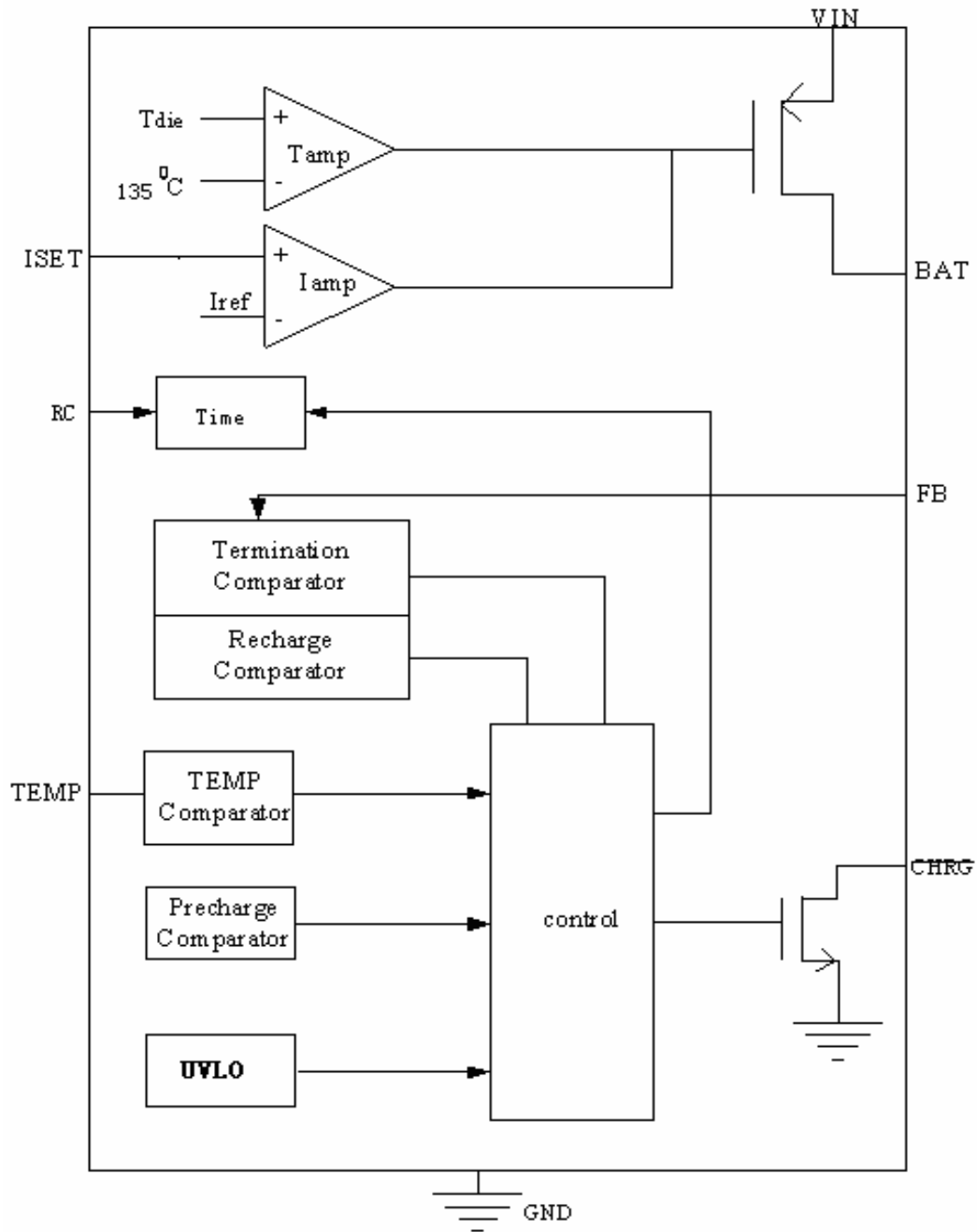

Figure 2 Block Diagram

CONSONANCE

Pin Description

Pin No.	Name	Function Description
1	TEMP	<p>Temperature Sense Input. Connecting TEMP pin to NTC thermistor. If TEMP pin's voltage is below 45% or above 80% of supply voltage V_{IN}, this means that battery's temperature is too high or too low, charging is suspended. If TEMP's voltage level is between 45% and 80% of supply voltage, battery fault state is released, and charging will resume.</p> <p>The temperature sense function can be disabled by grounding the TEMP pin.</p>
2	ISET	<p>Charge Current Setting and Monitoring Pin. The charge current is set by connecting a resistor R_{ISET} from this pin to GND. When in precharge mode, the ISET pin's voltage is regulated to 0.12V. When in constant current charge mode, the ISET pin's voltage is regulated to 1.205V. When maintenance mode, the ISET pin's voltage is regulated to 0.72V.</p> <p>The constant current is determined by:</p> $I_{CH} = 1218V / R_{ISET} \quad (A)$ <p>In the pre-charge mode, the charge current is 10% of the constant current. In the maintenance mode, the charge current is 60% of the constant current.</p>
3	GND	Ground Terminal.
4	VIN	Positive Input Supply Voltage. V_{IN} is the power supply to the internal circuit. When V_{IN} drops to within 10mv of the BAT pin voltage, CN3085 enters low-power sleep mode, dropping BAT pin's current to less than 3uA.
5	BAT	Battery Connection Pin. Connect the positive terminal of the battery to BAT pin. BAT pin provides charge current to the battery, and draws less than 3uA current in sleep mode.
6	RC	<p>Maintenance Charge Timer Setting Pin. Once the CN3085 enters into the maintenance charge mode, the charge timer is started, when the time out occurs, the whole charge cycle is terminated.</p> <p>The time limit is determined by the following equation:</p> $T = 2654 \times R5 \times C1 + 4980 \times C1 \times 10^3$ <p>Where,</p> <ul style="list-style-type: none"> ● T is the time limit in second ● R5 is the resistor from RC pin to VIN pin, the unit is ohm, R5 should range from 20kΩ to 5MΩ, otherwise the timer's accuracy may be affected. ● C1 is the capacitor from RC pin to GND, the unit is Farad, C1 should be greater than 1nF, otherwise the timer's accuracy may be affected.
7	\overline{CHRG}	Open Drain Charge Status Output. When the CN3085 is in the pre-charge, constant current and maintenance charge mode, \overline{CHRG} pin is pulled low by an internal switch, otherwise \overline{CHRG} pin is in high impedance state.
8	FB	<p>Battery voltage feedback input. Battery voltage is fed back to the CN3085 through this pin. The CN3085 determines the charge mode based on the FB pin voltage.</p> <p>As shown in Figure 1, the battery terminal voltage at BAT pin :</p> $V_{BAT} = V_{FB} \times (1 + R3 / R4)$

CONSONANCE

Absolute Maximum Ratings

All Terminal Voltage.....	-0.3V to 6.5V	Maximum Junction Temperature.....	150°C
BAT Short-Circuit Duration.....	Continuous	Operating Temperature.....	-40°C to 85°C
Storage Temperature.....	-65°C to 150°C	Lead Temperature(10s).....	260°C

Stresses beyond those listed under 'Absolute Maximum Ratings' may cause permanent damage to the device. These are stress ratings only and functional operation of the device at these or any other conditions above those indicated in the operational sections of the specifications is not implied. Exposure to Absolute Maximum Rating Conditions for extended periods may affect device reliability.

Electrical Characteristics

(VIN=5V, TA=-40°C to 85°C, Typical Values are measured at TA=25°C, unless otherwise noted))

Parameters	Symbol	Test Conditions	Min	Typ	Max	Unit
Input Supply Voltage	VIN		3.8		6	V
Operating Current	I _{VIN}	Charge Termination Mode	300	450	600	uA
Undervoltage Lockout	Vuvlo	VIN Rising		3.2	3.8	V
BAT pin Current	I _{BAT}	R _{ISET} =1.218K, V _{FB} =1V	850	1000	1150	mA
		R _{ISET} =1.218K, V _{FB} =0.5V	75	100	125	
		VIN=0V, sleep mode			3	uA
FB Pin						
FB Maximum Voltage	V _{MAX}	V _{FB} rising	1.192	1.205	1.218	V
FB Constant-Current Termination Threshold	V _{CCT}	V _{FB} rising	1.058	1.083	1.108	V
FB precharge threshold	V _{PRE}	V _{FB} rising		0.843		V
V _{PRE} Hysteresis	H _{PRE}			71		mV
FB Recharge Threshold	V _{RECH}	V _{FB} falling		1.052		V
Sleep Mode						
Sleep Mode Threshold	V _{SLP}	VIN falling, measures the voltage (VIN - V _{BAT})		10		mv
Sleep mode Release Threshold	V _{SLPR}	VIN rising, measures the voltage (VIN - V _{BAT})		60		mv
ISET Pin						
ISET Pin Voltage	V _{ISET}	Precharge mode		0.12		V
		Constant current charge mode		1.205		
		maintenance mode		0.72		
TEMP Pin						
High Threshold	V _{HIGH}	The voltage at TEMP rising	77.5	80	82.5	%V _{IN}
Low Threshold	V _{LOW}	The voltage at TEMP falling	42.5	45	47.5	%V _{IN}
TEMP input Current		TEMP to VIN or to GND			0.5	uA
CHRG Pin						
Sink Current	I _{CHRG}	V _{CHRG} =0.3V, charge mode		10		mA
Leakage Current		VIN=0V, V _{CHRG} =5.5V			1	uA

CONSONANCE

Detailed Description

The CN3085 is a battery charger IC for single to 3 cell nickel-metal hydride(NiMH) batteries. The device contains an on-chip power MOSFET and eliminates the need for the external sense resistor and blocking diode. The CN3085 requires minimal external components, very suitable for portable applications. Charge current can be programmed up to 1A with an external resistor.

The internal thermal regulation circuit reduces the programmed charge current if the die temperature attempts to rise above a preset value of approximately 135°C. This feature protects the CN3085 from excessive temperature, and allows the user to push the limits of the power handling capability of a given circuit board without risk of damaging the CN3085 or the external components. Another benefit of adopting thermal regulation is that charge current can be set according to typical, not worst-case, ambient temperatures for a given application with the assurance that the charger will automatically reduce the current in worst-case conditions.

The charge cycle begins when the voltage at the VIN pin rises above the UVLO level and greater than the voltage at BAT pin, The $\overline{\text{CHRG}}$ pin outputs a logic low when the CN3085 is in precharge, constant current and maintenance charge mode. At the beginning of the charge cycle, if the voltage at FB pin is below 0.843V, the CN3085 is in precharge mode and charge current is regulated at 10% of constant charge current. The CN3085 goes into the constant current charge mode once the voltage on the FB pin is above 0.843V and below 1.083V. In constant current mode, the charge current is set by R_{SET} at ISET pin. The CN3085 goes into the maintenance charge mode once the voltage at the FB pin rises above 1.083V. The charge current in maintenance mode is 60% of the constant charge current. An internal timer is started in the maintenance charge mode, this puts a time limit on the maintenance charge mode, the time limit is programmed by a resistor and a capacitor at the RC pin. After the time out occurs, the whole charge cycle is terminated, the charge current stops and $\overline{\text{CHRG}}$ pin assumes a high impedance state to indicate that the charging has stopped. The CN3085 will automatically start a new charge cycle if the voltage at FB pin drops below 87.3% of FB maximum voltage. When the input voltage is not present, the CN3085 goes into a sleep mode, dropping battery drain current to less than 3uA. This greatly reduces the current drain on the battery and increases the standby time. The typical charging profile is shown in Figure 3 and the operational flow chart is shown in Figure 4.

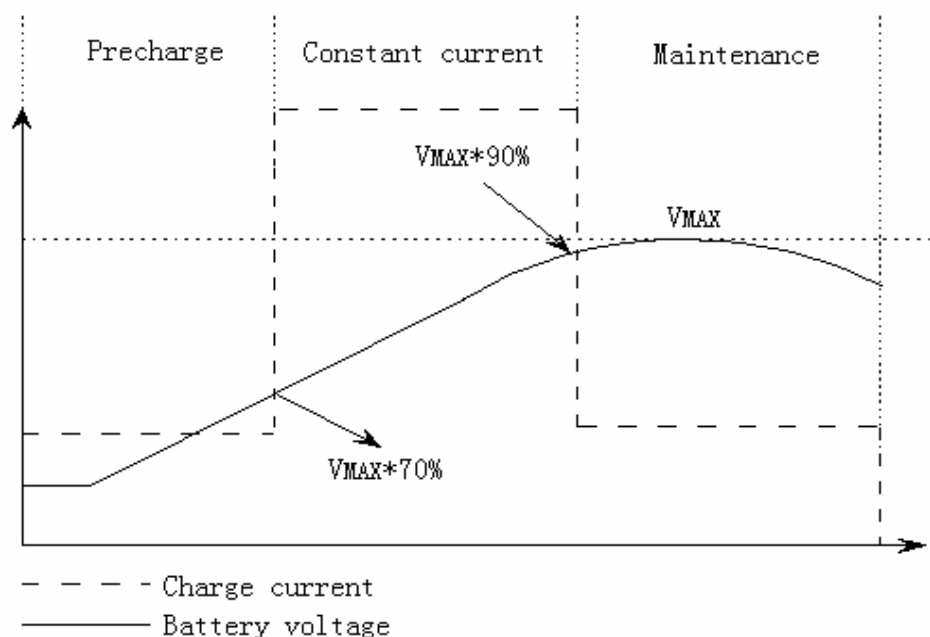

Figure 3 Typical Charging Profile

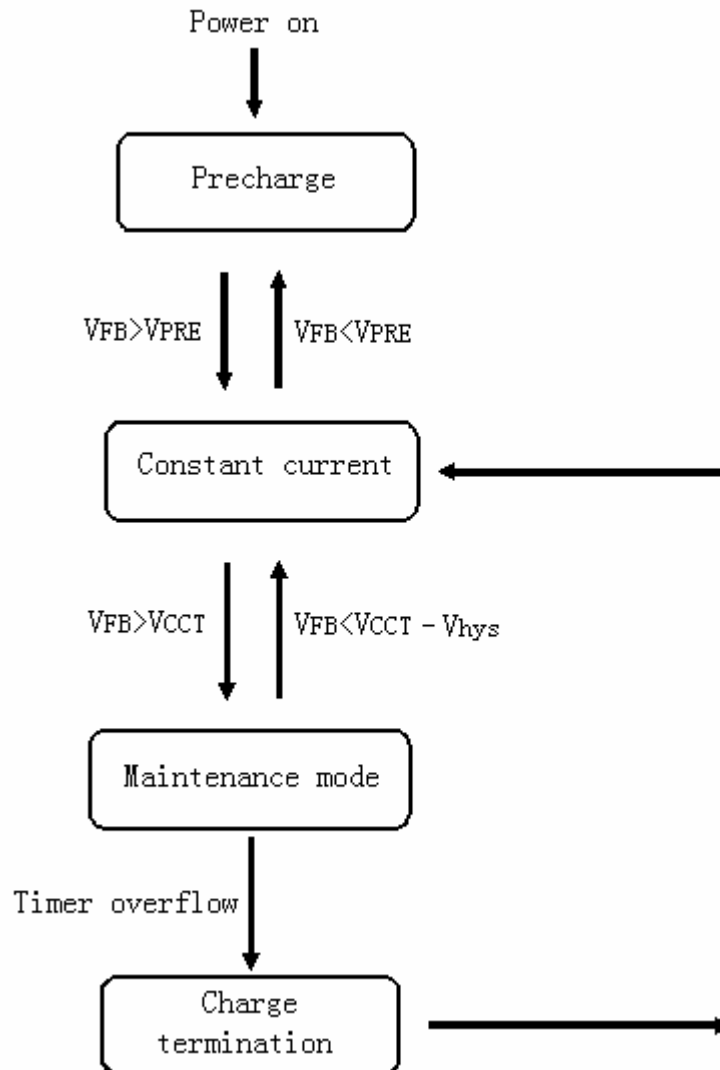

Figure 4 Operational Flow Chart

Application Information

Undervoltage Lockout (UVLO)

The CN3085 has an internal undervoltage lockout circuit that monitors the input voltage and keeps the charger in shutdown mode until V_{IN} rises above the undervoltage lockout voltage.

FB Voltage and the Battery Terminal Voltage

As shown in Figure 1, the battery terminal voltage is fed back to FB pin through the resistor divider formed by R3 and R4, the CN3085 determines the charge mode based on FB pin voltage.

The battery terminal voltage(BAT pin) can be found by:

$$V_{BAT} = V_{FB} \times (1 + R3 / R4)$$

The Maximum Battery Terminal Voltage

The maximum battery terminal voltage is the voltage that the battery may reach during the charge cycle, however, this is not necessarily happen due to the fact that NiMH battery's voltage may drop a bit when it is nearly full. Once the battery voltage reaches the maximum battery terminal voltage, it will be regulated at this level, not rise any more, and the charge current is kept not greater than 60% of the constant charge current. So

CONSONANCE

this is a protection mechanism to the battery.

When battery is absent, the voltage at BAT pin is the maximum battery terminal voltage, and $\overline{\text{CHRG}}$ pin outputs high impedance if BAT pin's loading current is less than 2.5mA(Typical).

Sleep mode

The CN3085 has an on-chip sleep-mode comparator, which keeps the charger in sleep mode if VIN falls below VBAT+10mv. Once in sleep mode, the charger will not come out of sleep mode until VIN rises 60mv above the battery voltage.

Precharge mode

If FB pin voltage falls below 0.843V, namely the battery voltage is below 70% of the maximum voltage of the battery terminal, the CN3085 goes into precharge mode, and the charge current is regulated at 10% of that in constant current charge mode.

Constant Current charge mode

If FB pin voltage is greater than 0.843V, and less than 1.083V, the CN3085 is in constant current charge mode. In the constant current charge mode, the charge current is determined by the following equation:

$$I_{CH} = 1218V / R_{ISET}$$

Where,

I_{CH} is the charge current in ampere

R_{ISET} is the resistance from ISET pin to GND, its unit is ohm

For example, if 1A charge current is needed:

$$R_{ISET} = 1218V/1A = 1.218k\Omega$$

For the stability over temperature and time, metal film resistance with 1% accuracy is recommended.

Maintenance Charge Mode

If the voltage at FB pin rises above 1.083V(90% of FB maximum voltage), the constant current charge mode is stopped, and the CN3085 goes into the maintenance charge mode. The charge current in maintenance mode is 60% of the constant charge current. An internal timer is started once the CN3085 is in the maintenance charge mode, this puts a time limit on the maintenance charge mode, the time limit is programmed by a resistor and a capacitor at the RC pin as shown in Figure 1. After the time out occurs, the whole charge cycle is terminated, the CN3085 enters into termination mode.

In maintenance charge mode, the time limit is determined by the following equation:

$$T=2654 \times R5 \times C1+4980 \times C1 \times 10^3$$

Where:

- T is the time limit in second
- R5 is the resistor from RC pin to VIN pin, the unit is ohm, R5 should range from 20kΩ to 5MΩ, otherwise, the timer's accuracy may be affected.
- C1 is the capacitor from RC pin to GND, the unit is Farad, C1 should be greater than 1nF, otherwise, the timer's accuracy may be affected.

The Constant-Current Termination Voltage

As shown in Figure 1, the battery voltage is fed back to FB bin through the resistor divider formed by R3 and R4, the CN3085 determine the charge mode based on the FB pin's voltage. Once the voltage at FB pin rises above 1.083V, the CN3085 stops the constant current charge and enters into the maintenance charge mode, at this time the corresponding voltage at BAT pin is determined by the following equation:

$$V_{BAT} = 1.205 \times 90\% \times (1 + R3/R4)$$

This is the constant-current termination voltage, which is a very important parameter, if it is set too low, it will take longer time to fully charge the battery in maintenance mode; If it is set too high, the constant-current charge mode may not be terminated due to the fact that NiMH battery's voltage may drop a bit when it is nearly

CONSONANCE

full. Hence, the constant-current termination voltage should be carefully designed.

When designing the constant-current termination voltage, the battery's internal resistance and the parasitic resistance from the PCB to the battery's terminals should be taken into considerations. As shown in Figure 5, R_B is the battery's internal resistance, R_W is the parasitic resistance including the metal wire's resistance, plug's contact resistance, etc.

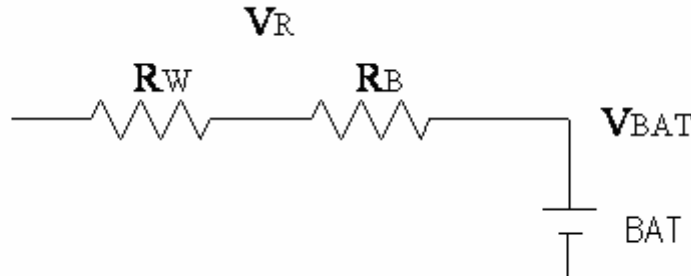

Figure 5 battery's internal resistance and parasitic resistance

In the constant current charge mode, charge current flows through the resistor R_B and R_W , a voltage drop V_R is generated. Assume that the true battery voltage is V_{BAT} , but the detected voltage by CN3085 is $V_{BAT} + V_R$, which does not accurately reflect the battery voltage. Therefore, when designing the constant-current termination voltage, the voltage drop V_R should be considered.

Recharge

In charge termination mode, if the voltage at FB pin drops below 1.052V (87.3% of FB maximum voltage), the CN3085 will begin a new charge cycle. A new charge cycle can also be started by removing the input voltage and reapplying it.

Battery Temperature Sense

To prevent the damage caused by the very high or very low temperature done to the battery pack, the CN3085 continuously monitors battery pack temperature by measuring the voltage at TEMP pin determined by the voltage divider circuit and the battery's internal NTC thermistor as shown in Figure 1.

The CN3085 compares the voltage at TEMP pin (V_{TEMP}) against its internal V_{LOW} and V_{HIGH} thresholds to determine if charging is allowed. In CN3085, V_{LOW} is fixed at $(45\% \times V_{IN})$, while V_{HIGH} is fixed at $(80\% \times V_{IN})$. If $V_{TEMP} < V_{LOW}$ or $V_{TEMP} > V_{HIGH}$, it means that the battery temperature is too high or too low and the charge cycle is suspended. When V_{TEMP} is between V_{LOW} and V_{HIGH} , the charge cycle resumes.

The battery temperature sense function can be disabled by connecting TEMP pin to GND.

Selecting R1 and R2

The values of R1 and R2 in Figure 1 can be determined according to the assumed temperature monitor range and thermistor's values. The Follows is an example:

Assume temperature monitor range is $T_L \sim T_H$ ($T_L < T_H$); the thermistor in battery has negative temperature coefficient (NTC), R_{TL} is thermistor's resistance at T_L , R_{TH} is the resistance at T_H , so $R_{TL} > R_{TH}$, then at temperature T_L , the voltage at TEMP pin is:

$$V_{TEMPL} = \frac{R_2 \parallel R_{TL}}{R_1 + R_2 \parallel R_{TL}} \times V_{IN}$$

At temperature T_H , the voltage at TEMP pin is:

$$V_{TEMPH} = \frac{R_2 \parallel R_{TH}}{R_1 + R_2 \parallel R_{TH}} \times V_{IN}$$

CONSONANCE

We know, $V_{\text{TEMPL}} = V_{\text{HIGH}} = k_2 \times V_{\text{IN}}$ ($k_2 = 0.8$)

$V_{\text{TEMPH}} = V_{\text{LOW}} = k_1 \times V_{\text{IN}}$ ($k_1 = 0.45$)

Then we can have:

$$R1 = \frac{R_{\text{TL}} R_{\text{TH}} (k_2 - k_1)}{(R_{\text{TL}} - R_{\text{TH}}) k_1 k_2}$$

$$R2 = \frac{R_{\text{TL}} R_{\text{TH}} (k_2 - k_1)}{R_{\text{TL}} (k_1 - k_1 k_2) - R_{\text{TH}} (k_2 - k_1 k_2)}$$

Likewise, for positive temperature coefficient thermistor in battery, we have $R_{\text{TH}} > R_{\text{TL}}$ and we can calculate:

$$R1 = \frac{R_{\text{TL}} R_{\text{TH}} (k_2 - k_1)}{(R_{\text{TH}} - R_{\text{TL}}) k_1 k_2}$$

$$R2 = \frac{R_{\text{TL}} R_{\text{TH}} (k_2 - k_1)}{R_{\text{TH}} (k_1 - k_1 k_2) - R_{\text{TL}} (k_2 - k_1 k_2)}$$

We can conclude that temperature monitor range is independent of power supply voltage V_{IN} and it only depends on $R1$, $R2$, R_{TL} and R_{TH} . The values of R_{TH} and R_{TL} can be found in thermistor handbook or deduced from testing data.

In actual application, if only one terminal temperature is concerned (normally protecting overheating), there is no need to use $R2$ but $R1$. In this case it becomes very simple to calculate $R1$.

Constant-Current/ Constant-Temperature

The CN3085 use a unique architecture to charge a battery in a constant-current, constant temperature fashion as shown in Figure 2. Whether in the pre-charge mode or in the constant current charge mode, or in maintenance charge mode, if the CN3085's power dissipation results in the device's junction temperature approaching 135°C , amplifier T_{amp} begin to control the charging current, the device's junction temperature remained at about 135°C .

Open-Drain Status Outputs

The CN3085 have an open-drain status output $\overline{\text{CHRG}}$. $\overline{\text{CHRG}}$ is pulled low when the charger is in precharge, constant current charge or maintenance charge mode, otherwise, becomes high impedance (including battery's absence and battery temperature abnormality).

When battery is absent, the voltage at BAT pin is the maximum battery terminal voltage, and $\overline{\text{CHRG}}$ pin outputs high impedance if BAT pin's loading current is less than 2.5mA (Typical).

If charging status indication function is not needed, connect $\overline{\text{CHRG}}$ pin to ground.

VIN Bypass Capacitor CIN

In most applications, a high-frequency bypass capacitor at the input is needed. Generally A 1uF ceramic capacitor, placed in close proximity to V_{IN} and GND pins, works well. In some applications depending on the power supply characteristics and cable length, it may be necessary to increase the capacitor's value. For the consideration of the bypass capacitor, please refer to the Application Note AN102 from our website.

About Timing Capacitor

In the application circuit of Figure 1, if MLCC ceramic capacitor is used as the timing capacitor $C1$, special attention should be given to the capacitor's voltage coefficient. Some MLCC ceramic capacitor demonstrates negative voltage coefficient, which will decrease the capacitance if a DC voltage is applied.

The average DC voltage on the timing capacitor is about 50% of input supply when CN3085's timer is functioning. The capacitor's datasheet should be carefully checked to determine the actual capacitance.

Stability

Typically a 4.7uF to 10uF capacitor from BAT pin to GND is required to stabilize the feedback loop.

In constant current mode, the stability is also affected by the impedance at the ISET pin. With no additional

CONSONANCE

capacitance on the ISET pin, the loop is stable with current set resistors values as high as 50K Ω . However, additional capacitance on ISET pin reduces the maximum allowed current set resistor. The pole frequency at ISET pin should be kept above 200KHz. Therefore, if ISET pin is loaded with a capacitance C, the following equation should be used to calculate the maximum resistance value for R_{ISET}:

$$R_{ISET} < 1 / (6.28 \times 2 \times 10^5 \times C)$$

Board Layout Considerations

1. R_{ISET} at ISET pin should be as close to CN3085 as possible, also the parasitic capacitance at ISET pin should be kept as small as possible.
2. The capacitance at VIN pin and BAT pin should be as close to CN3085 as possible.
3. During charging, CN3085's temperature may be high, the NTC thermistor should be placed far enough to CN3085 so that the thermistor can reflect the battery's temperature correctly.
4. It is very important to use a good thermal PCB board layout to maximize charging current. The thermal path for the heat generated by the IC is from the die to the copper lead frame through the package lead (especially the ground lead) to the PCB board copper, the PCB board copper is the heat sink. The footprint copper pads should be as wide as possible and expand out to larger copper areas to spread and dissipate the heat to the surrounding ambient. Feedthrough vias to inner or backside copper layers are also useful in improving the overall thermal performance of the charger. Other heat sources on the board, not related to the charger, must also be considered when designing a PCB board layout because they will affect overall temperature rise and the maximum charge current. The ability to deliver maximum charge current under all conditions require that the exposed metal pad on the back side of the CN3085 package be soldered to the PCB board ground. Failure to make the thermal contact between the exposed pad on the backside of the package and the copper board will result in larger thermal resistance.

CONSONANCE

Package Information

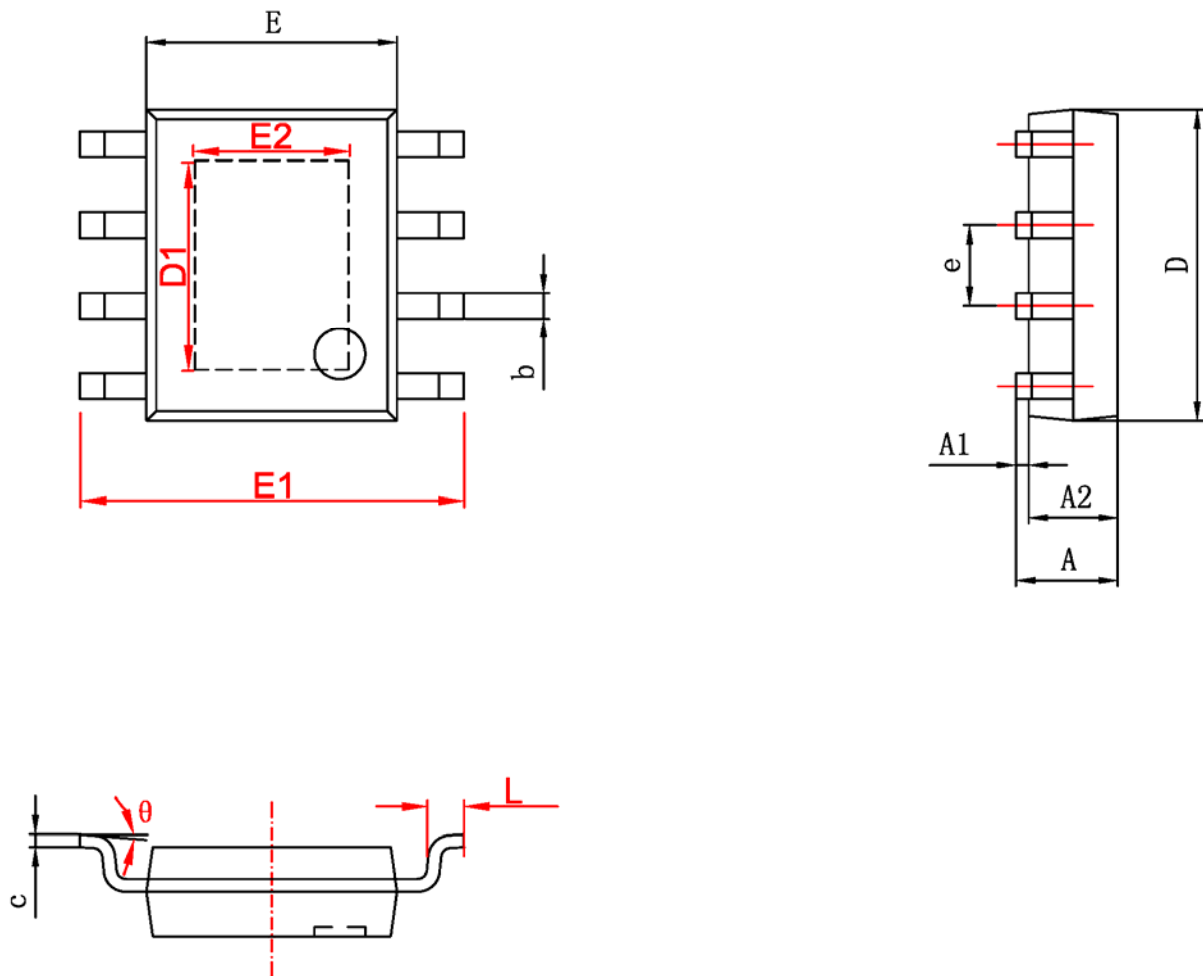

字符	Dimensions In Millimeters		Dimensions In Inches	
	Min	Max	Min	Max
A	1.350	1.750	0.053	0.069
A1	0.050	0.150	0.004	0.010
A2	1.350	1.550	0.053	0.061
b	0.330	0.510	0.013	0.020
c	0.170	0.250	0.006	0.010
D	4.700	5.100	0.185	0.200
D1	3.202	3.402	0.126	0.134
E	3.800	4.000	0.150	0.157
E1	5.800	6.200	0.228	0.244
E2	2.313	2.513	0.091	0.099
e	1.270 (BSC)		0.050 (BSC)	
L	0.400	1.270	0.016	0.050
θ	0°	8°	0°	8°

Consonance does not assume any responsibility for use of any circuitry described. Consonance reserves the right to change the circuitry and specifications without notice at any time.